

SYSTEM BNP-HO

High-Output Ballast-Operated Cold Cathode

Photometry

System type: BNP-HO (high-output ballast-operated cold cathode)
Lamp operating current: 200 mA

CATALOG NUMBER: BNP-HO
LUMINAIRE: ASSEMBLED PLYWOOD COVE PAINTED WHITE, NO ENCLOSURE
LAMPS: ONE 4' 25MM 42TC COLD CATHODE LAMP RATED AT 2588 LUMENS
BALLAST: CATHODE LIGHTING SYSTEMS
MOUNTING: WALL
LUMEN TO CANDELA RATIO USED = 9.18
TOTAL INPUT WATTS = 48.4 AT 200 MA OPERATING CURRENT
THE 0 DEGREE PLANE IS PERPENDICULAR TO THE LAMPS.

CANDELA DISTRIBUTION										FLUX
	0.0	22.5	45.0	67.5	90.0	112.5	135.0	157.5	180.0	
0	0	0	0	0	0	0	0	0	0	0
5	0	0	0	0	0	0	0	0	0	0
15	0	0	0	0	0	0	0	0	0	0
25	0	0	0	0	0	0	0	0	0	0
35	0	1	1	0	0	0	0	2	0	1
45	4	15	16	9	1	7	11	7	0	7
55	17	23	30	24	8	15	21	9	0	16
65	52	58	51	51	7	35	22	9	0	32
75	96	103	88	65	12	38	24	11	0	52
85	154	161	142	100	20	46	29	13	0	81
90	189	197	175	127	26	49	30	13	0	
95	278	305	280	206	52	56	32	13	0	148
105	553	526	431	289	131	69	35	13	0	232
115	616	586	498	375	229	97	37	13	0	265
125	659	629	554	452	321	148	37	14	0	280
135	683	660	605	508	405	343	111	26	3	289
145	700	681	631	552	472	417	191	120	108	273
155	692	672	635	580	525	487	449	343	333	240
165	664	647	626	593	561	538	517	498	505	161
175	619	606	601	590	581	571	566	560	567	56
180	585	585	585	585	585	585	585	585	585	

ZONAL LUMEN SUMMARY			
ZONE	LUMENS	%LAMP	%FIXT
0-30	0	0.0	0.0
0-40	1	0.0	0.0
0-60	23	0.9	1.1
0-90	189	7.3	8.8
90-120	644	24.9	30.2
90-130	924	35.7	43.3
90-150	1487	57.5	69.7
90-180	1944	75.1	91.2
0-180	2133	82.4	100.0

TOTAL LUMINAIRE EFFICIENCY: 82.4%
TOTAL REFLECTANCE OF PAINT: 90.1%
CIE TYPE: INDIRECT

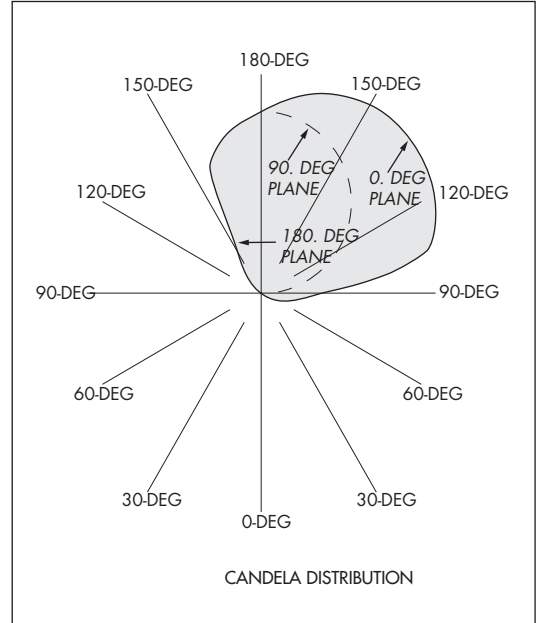
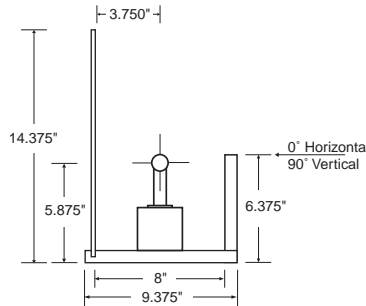

Complete photometric information is available on our website at www.CathodeLightingSystems.com. Files are in standard IES format and may be downloaded from the *Photometrics* section.

RC	80				70				50				30				10				0
	70	50	30	10	70	50	30	10	50	30	10	50	30	10	50	30	10	50	30	10	
0	80	80	80	80	70	70	70	70	50	50	50	32	32	32	15	15	15	7			
1	72	68	64	61	62	59	56	53	41	40	38	26	25	23	11	11	10	3			
2	65	58	53	49	56	50	46	42	35	33	30	22	20	18	9	8	7	2			
3	59	51	45	40	50	44	39	35	31	28	25	19	17	15	8	7	6	1			
4	53	45	38	33	46	39	33	29	27	24	21	17	14	13	7	6	5	1			
5	49	39	33	28	42	34	29	24	24	20	17	15	12	11	6	5	4	0			
6	45	35	29	24	38	30	25	21	21	18	15	13	11	9	5	4	3	0			
7	41	31	25	21	35	27	22	18	19	16	13	12	9	8	5	4	3	0			
8	38	28	22	18	33	24	19	16	17	14	11	11	8	7	4	3	2	0			
9	35	26	20	16	30	22	17	14	16	12	10	10	7	6	4	3	2	0			
10	33	23	18	14	28	20	15	12	14	11	9	9	7	5	4	3	2	0			

COEFFICIENTS OF UTILIZATION - ZONAL CAVITY METHOD
EFFECTIVE FLOOR CAVITY REFLECTANCE 0.20

NOTE:
The zonal cavity calculation technique is accurate when luminaires within the symmetric candela distributions are employed and when the luminaires are located symmetrically throughout the room. This unit has special characteristics. Therefore these coefficients should be used with caution.

SYSTEM BNP-HO

High-Output Ballast-Operated Cold Cathode

Photometry (cont'd.)

COLD CATHODE LAMP LUMENS PER FOOT

Lamp Color	Catalog Number	Lumens per Foot System BNP-HO (200 mA lamp current)
Incandescent White	28TC	665
Warm White	30TC	709
Soft White	35TC	687
Cool White	42TC	647
Ice White	50TC	659
Daylight	65TC	681
Pink White	PW	432
Hot Pink	HP	396
Ruby Red	RR	144
Lavender	LV	468
Purple	PR	360
Deep Purple	DP	72
Blue	SB	612
Deep Blue	DB	504
Cobalt Blue	CB	390
Turquoise	TQ	710
Aquamarine	AQ	576
Green	GR	720
Emerald Green	EG	324
Gold	GD	364
Novial Gold	NG	252
Canary Yellow	CY	392
Orange	OR	288

TYPICAL LUMEN MAINTENANCE FOR COLD CATHODE LAMPS

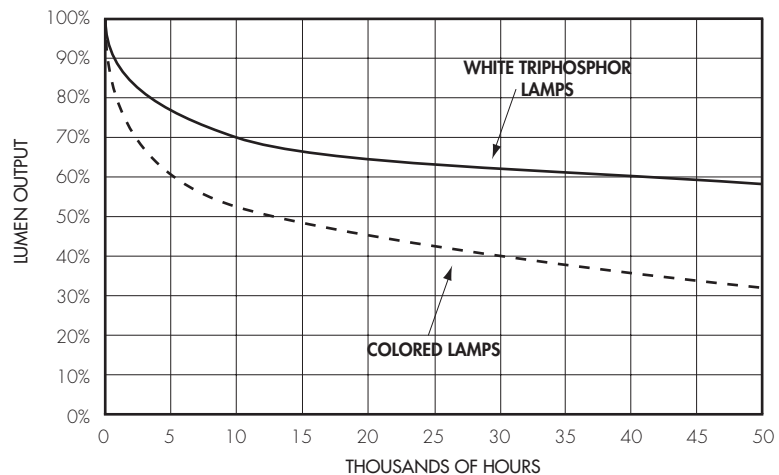

Photometric information by ITL (Independent Test Laboratories), Boulder, CO; ITL (Luminaire Testing Laboratory), Allentown, PA; and Cathode Lighting Systems Inc.