

# SYSTEM BNP-EX

Standard-Output Ballast-Operated Cold Cathode for Export

Recommended Cove Profiles:  
Surface-Mounted Lampholders

The following diagrams depict typical clearances within coves required to accommodate surface-mounted lampholders and lamps when utilizing system BNP-EX.

BL (surface-mounted) lampholder mounted to a horizontal surface

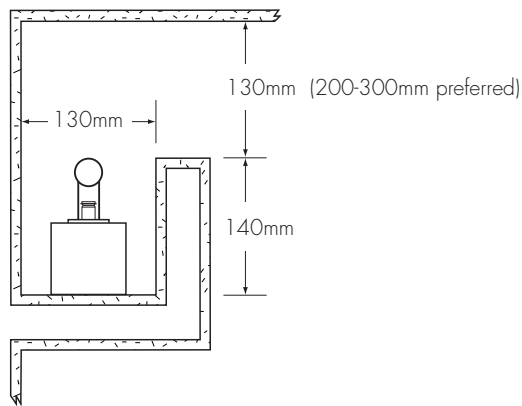

BL (surface-mounted) lampholder mounted to a vertical surface

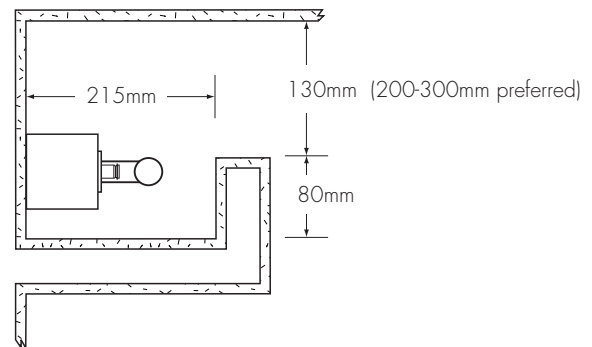

BL (surface-mounted) lampholder mounted in a downward-hanging configuration

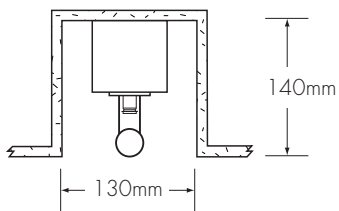

Note: This mounting configuration is restricted to specific types of installations and lamp shapes. Please refer to the *Lampholder Mounting & Lamp Shape Compatibility* page in the *Introduction to Cold Cathode* section.

Inner surfaces of coves should be finished with drywall, plaster, fire-rated plywood, or other suitable material and painted matte white. This not only serves to properly reflect the light but also provides a surface on which to mount the lampholders. Dimensions shown are minimums, but coves should be as deep and wide as possible to provide the most uniform illumination. Vaulted or curved ceilings will generally increase the spread of light from within the cove to the surrounding ceiling area. Cove fascias may need to be increased beyond heights shown so that lamps will not be visible from vantage points that are higher than ground level (stairs, ramps, etc.).

*Drawings not to scale*

# SYSTEM BNP-EX

Standard-Output Ballast-Operated Cold Cathode for Export

Recommended Cove Profiles:  
Surface-Mounted Lampholders (cont'd.)

A double row of BL (surface-mounted)  
lampholders mounted to a horizontal surface

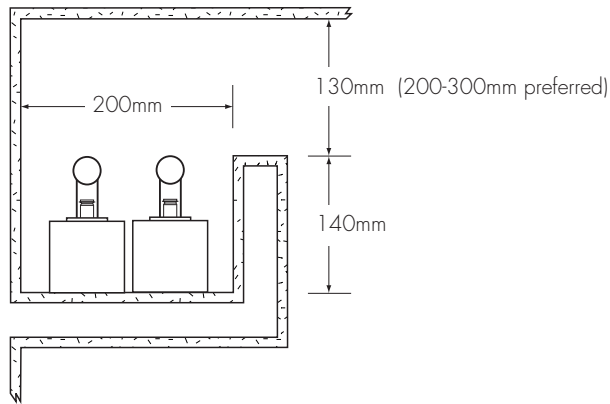

A triple row of BL (surface-mounted)  
lampholders mounted to a horizontal surface

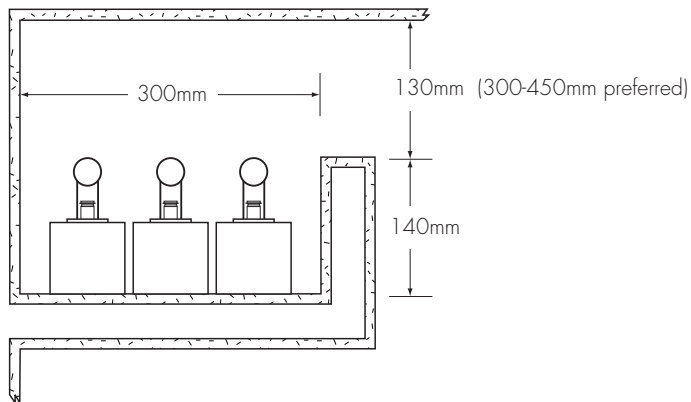

*Drawings not to scale*

© 2002 Cathode Lighting Systems Inc.

8020 Queenair Drive, Gaithersburg, MD 20879 • ph: 301 921 4120 • fax: 301 963 3050  
e-mail: [info@CathodeLightingSystems.com](mailto:info@CathodeLightingSystems.com) • website: [www.CathodeLightingSystems.com](http://www.CathodeLightingSystems.com)

**EE-8**

**CLS** CATHODE  
LIGHTING  
SYSTEMS

# SYSTEM BNP-EX

Standard-Output Ballast-Operated Cold Cathode for Export

Recommended Cove Profiles:  
Recess-Mounted Lampholders

The following diagrams depict typical clearances within coves required to accommodate recess-mounted lampholders and lamps when utilizing system BNP-EX.

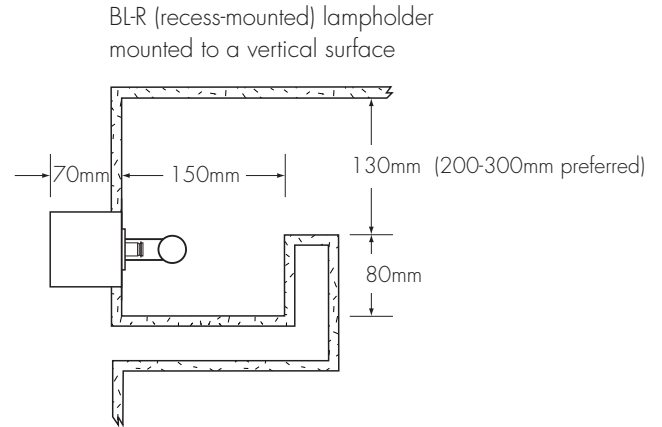
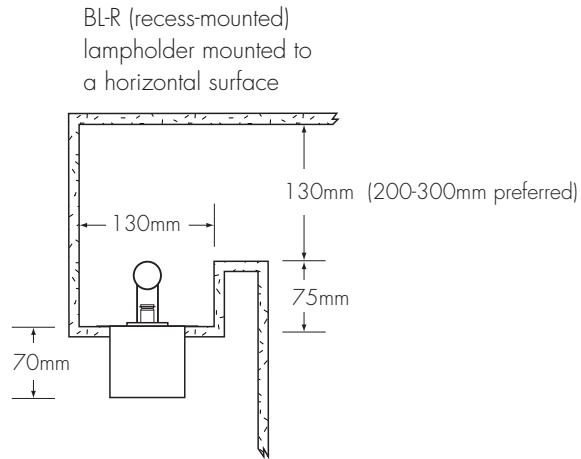

Note: This mounting configuration is restricted to specific types of installations and lamp shapes. Please refer to the *Lampholder Mounting & Lamp Shape Compatibility* page in the *Introduction to Cold Cathode* section.

BL-R (recess-mounted) lampholder mounted in a downward-hanging configuration

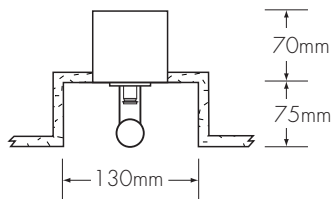

A double row of BL-R (recess-mounted) lampholders mounted to a horizontal surface

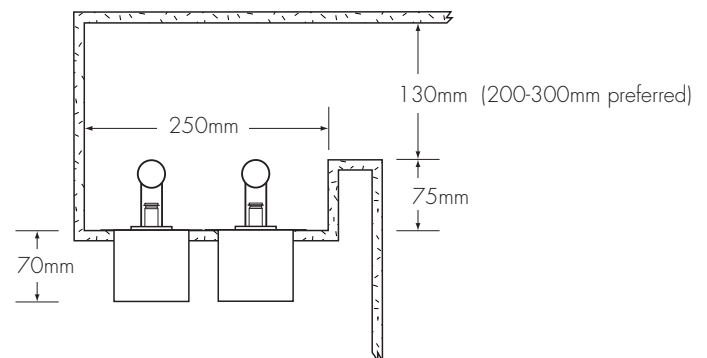

Inner surfaces of coves should be finished with drywall, plaster, fire-rated plywood, or other suitable material and painted matte white. This not only serves to properly reflect the light but also provides a surface on which to mount the lampholders. Dimensions shown are minimums, but coves should be as deep and wide as possible to provide the most uniform illumination. Vaulted or curved ceilings will generally increase the spread of light from within the cove to the surrounding ceiling area. Cove fascias may need to be increased beyond heights shown so that lamps will not be visible from vantage points that are higher than ground level (stairs, ramps, etc.).

*Drawings not to scale*

# SYSTEM BNP-EX

Standard-Output Ballast-Operated Cold Cathode for Export

Recommended Cove Profiles:  
Recess-Mounted Lampholders (cont'd.)

A triple row of BL-R (recess-mounted) lampholders mounted to a horizontal surface

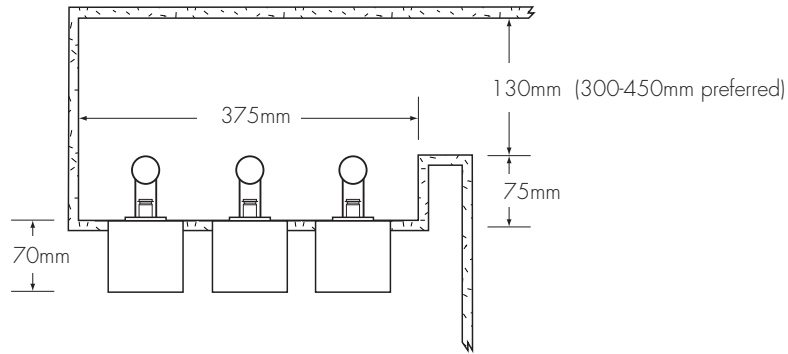

BL-R (recess-mounted) lampholder mounted to a vertical surface for an exposed sculptural lamp application

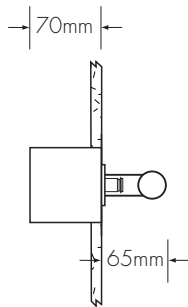

BL-R (recess-mounted) lampholder mounted to a horizontal surface for an exposed sculptural lamp application

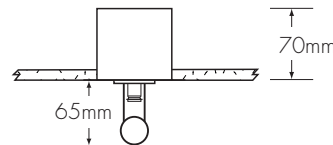

Note: This mounting configuration is restricted to specific types of installations and lamp shapes. Please refer to the *Lampholder Mounting & Lamp Shape Compatibility* page in the *Introduction to Cold Cathode* section.

Drawings not to scale

© 2002 Cathode Lighting Systems Inc.

EE-10

8020 Queenair Drive, Gaithersburg, MD 20879 • ph: 301 921 4120 • fax: 301 963 3050  
e-mail: info@CathodeLightingSystems.com • website: www.CathodeLightingSystems.com

**CLS** CATHODE  
LIGHTING  
SYSTEMS